

TB 9-6625-1976-35

CHANGE 1

DEPARTMENT OF THE ARMY TECHNICAL BULLETIN

**CALIBRATION PROCEDURE FOR
AC CALIBRATOR, JOHN FLUKE, MODEL 5200A
AND
PRECISION POWER AMPLIFIERS,
JOHN FLUKE, MODELS 5215A AND 5205A**

Headquarters, Department of the Army, Washington, DC

19 January 2006

Distribution Statement A: Approved for public release; distribution is unlimited.

TB 9-6625-1976-35, 5 October 2004, is changed as follows:

1. Remove old pages and insert new pages as indicated below. New or changed material is indicated by a vertical bar in the margin of the page.

Remove Pages

3 and 4
7 and 8
9 and 10
19 and 20

Insert Pages

3 and 4
7 and 8
9 and 10
19 and 20

2. File this change sheet in front of the publication for reference purposes.

By Order of the Secretary of the Army:

Official:

SANDRA R. RILEY

Administrative Assistant to the
Secretary of the Army

0532602

PETER J. SCHOOMAKER
General, United States Army
Chief of Staff

Distribution:

To be distributed in accordance with IDN 343047, requirements for calibration procedure
TB 9-6625-1976-35.

***TB 9-6625-1976-35**

DEPARTMENT OF THE ARMY TECHNICAL BULLETIN

CALIBRATION PROCEDURE FOR AC CALIBRATOR, JOHN FLUKE, MODEL 5200A AND PRECISION POWER AMPLIFIERS, JOHN FLUKE, MODELS 5215A AND 5205A

Headquarters, Department of the Army, Washington, DC
5 October 2004

Distribution Statement A: Approved for public release; distribution is unlimited.

REPORTING OF ERRORS AND RECOMMENDING IMPROVEMENTS

You can improve this manual. If you find any mistakes or if you know of a way to improve these procedures, please let us know. Mail your letter or DA Form 2028 (Recommended Changes to Publications and Blank Forms) directly to: Commander, US Army Aviation and Missile Command, AMSAM-MMC-MA-NP, Redstone Arsenal, AL 35898-5000. A reply will be furnished to you. You may also provide DA Form 2028 information to AMCOM via e-mail, fax, or the World Wide Web. Our fax number is DSN 788-6546 or Commercial 256-842-6546. Our e-mail address is 2028@redstone.army.mil. Instructions for sending an electronic 2028 may be found at the back of this manual. For the World Wide Web, use <https://amcom2028.redstone.army.mil>.

SECTION		Paragraph	Page
I.	IDENTIFICATION AND DESCRIPTION		
	Test instrument identification	1	2
	Forms, records, and reports.....	2	2
	Calibration description	3	2
II.	EQUIPMENT REQUIREMENTS		
	Equipment required.....	4	4
	Accessories required	5	4
III.	CALIBRATION PROCESS FOR AC CALIBRATOR, JOHN FLUKE, MODEL 5200A		
	Preliminary instructions	6	5
	Equipment setup.....	7	5
	Frequency accuracy.....	8	6
	Distortion.....	9	8
	Voltage accuracy and linearity (reference level only).....	10	9
	Voltage accuracy and linearity (transfer level only)	11	11
	Power supply	12	15
	Final procedure	13	15

*This bulletin supersedes TB 9-6625-1976-35, dated 6 September 1994.

SECTION		Paragraph	Page
IV.	CALIBRATION PROCESS FOR PRECISION POWER AMPLIFIERS, JOHN FLUKE, MODELS 5215A AND 5205A		
	Preliminary instructions	14	15
	Equipment setup	15	16
	High voltage accuracy (reference level)	16	16
	High voltage accuracy (transfer level only)	17	18
	Distortion	18	19
	Power supply (model 5215A)	19	20
	Final procedure	20	20

**SECTION I
IDENTIFICATION AND DESCRIPTION**

1. Test Instrument Identification. This bulletin provides instructions for the calibration of Ac Calibrator, Fluke, Model 5200A and Precision Power Amplifiers, Fluke, Models 5215A and 5205A. The manufacturer's manuals were used as the prime data sources in compiling these instructions. The equipment being calibrated will be referred to as the TI (test instrument) throughout this bulletin.

a. Model Variations. Variations among models are described in text.

b. Time and Technique. The time required for this calibration is approximately 6 hours, using the dc and low frequency technique.

2. Forms, Records, and Reports.

a. Forms, records and reports required for calibration personnel at all levels are prescribed by TB 750-25.

b. Adjustments to be reported are designated (R) at the end of the sentence in which they appear. When adjustments are in tables, the (R) follows the designated adjustment. Report only those adjustments made and designated with (R).

3. Calibration Description. TI parameters and performance applications which pertain to this calibration are in table 1.

Table 1. Calibration Description

Test instrument parameters		Performance specifications	
Frequency		Range: 10 Hz to 1.2 MHz Accuracy: 100 Hz to 100 kHz ranges: $\pm(1\% \text{ of setting} + 0.1\% \text{ of range})$ 1 MHz range: $\pm(3\% \text{ of setting} + 0.3\% \text{ of range})$	
Line regulation		$\pm 0.001\%$ of setting for a 10% change in line voltage	
Distortion and noise ¹		10 Hz to 100 kHz: $\pm(0.04\% \text{ of setting} + 10 \mu\text{V})$ 100 to 500 kHz: $\pm(0.3\% \text{ of setting} + 30 \mu\text{V})$ 500 kHz to 1 MHz: $\pm(1\% \text{ of setting} + 30 \mu\text{V})$	
Output voltage (reference)			
Frequency	1, 10, and 100 V ranges	1, 10, and 100 mV ranges	1000 V range
10 to 30 Hz	$\pm(0.1\% \text{ of setting} + 0.005\% \text{ of range})$	$\pm(0.1\% \text{ of setting} + 10 \mu\text{V})$	$\pm(0.12\% \text{ of setting} + 0.005\% \text{ of range})$
30 Hz to 20 kHz	$\pm(0.02\% \text{ of setting} + 0.002\% \text{ of range})$	$\pm(0.02\% \text{ of setting} + 10 \mu\text{V})$	$\pm(0.04\% \text{ of setting} + 0.002\% \text{ of range})$
20 to 50 kHz	$\pm(0.05\% \text{ of setting} + 0.005\% \text{ of range})$	$\pm(0.05\% \text{ of setting} + 20 \mu\text{V})$	$\pm(0.08\% \text{ of setting} + 0.005\% \text{ of range})$
50 to 100 kHz	$\pm(0.05\% \text{ of setting} + 0.005\% \text{ of range})$	$\pm(0.05\% \text{ of setting} + 20 \mu\text{V})$	$\pm(0.10\% \text{ of setting} + 0.01\% \text{ of range})$
0.1 to 1 MHz	$\pm(0.33\% \text{ of setting} + 0.03\% \text{ of range})$	$\pm(0.33\% \text{ of setting} + 30 \mu\text{V})$	Not applicable
Output voltage (transfer)			
Frequency	1, 10, and 100 V ranges	1, 10, and 100 mV ranges	1000 V range ²
10 to 30 Hz	$\pm(0.12\% \text{ of setting} + 0.005\% \text{ of range})$	$\pm(0.12\% \text{ of setting} + 10 \mu\text{V})$	$\pm(0.12\% \text{ of setting at } 500 \text{ V or less})$ $(0.4\% \text{ of setting at } 1000 \text{ V})$
30 Hz to 20 kHz	$\pm(0.12\% \text{ of setting} + 0.002\% \text{ of range})$	$\pm(0.12\% \text{ of setting} + 10 \mu\text{V})$	$\pm(0.12\% \text{ of setting at } 500 \text{ V or less})$ $(0.4\% \text{ of setting at } 1000 \text{ V})$
20 to 50 kHz	$\pm(0.12\% \text{ of setting} + 0.005\% \text{ of range})$	$\pm(0.12\% \text{ of setting} + 10 \mu\text{V})$	$\pm(0.12\% \text{ of setting})$
50 to 100 kHz	$\pm(1.2\% \text{ of setting} + 0.005\% \text{ of range})$	$\pm(1.2\% \text{ of setting} + 10 \mu\text{V})$	$\pm(1.2\% \text{ of setting})$
0.1 to 1 MHz	$\pm(1.2\% \text{ of setting} + 0.03\% \text{ of range})$	$\pm(1.2\% \text{ of setting} + 30 \mu\text{V})$	Not applicable

¹Distortion not verified for frequencies >50 kHz due to limitation of standards. Paragraph 9 lists specifications for distortion at specific points when indicated load is applied to model 5200A. Paragraph 18 lists specifications for distortion at specific points for models 5215A and 5205A.

²At transfer level, AC voltage level measurements are limited to 700 V ac due to limitation of standards.

**SECTION II
EQUIPMENT REQUIREMENTS**

4. Equipment Required. Table 2 identifies the specific equipment to be used in this calibration procedure. This equipment is issued with Secondary Transfer Calibration Standards Set AN/GSM-287, AN/GSM-705, and Secondary Reference Calibration Standards Set NSN 4931-00-621-7878. Alternate items may be used by the calibrating activity. The item selected must be verified to perform satisfactorily prior to use and must bear evidence of current calibration. The equipment must meet or exceed the minimum use specifications listed in table 2. The accuracies listed in table 2 provide a four-to-one ratio between the standard and TI. Where the four-to-one ratio cannot be met, the four-to-one accuracy will be listed, and the actual accuracy of the equipment selected is shown in parenthesis.

5. Accessories Required. The accessories required for this calibration are common usage accessories, issued as indicated in paragraph 4 above, and are not listed in this calibration procedure.

Table 2. Minimum Specifications of Equipment Required

Common name	Minimum use specifications	Manufacturer and model (part number)
AC MEASUREMENT STD (MEASUREMENT STD)	Range: 1 to 1000V Accuracy: $\pm 0.0055\%$ ($\pm 0.01\%$)	Fluke Model 5790A (13534003)
AUDIO ANALYZER	Range: 20 Hz to 50 kHz Accuracy: Measure less than .041% distortion	Boonton, Model 1121 (1121)
CALIBRATOR ¹	Ac voltage: Range: 1.0 to 1000 V Frequency: 20 Hz to 1 MHz Accuracy: $\pm .03$ to $.31\%$ (depending on voltage and frequency)	Fluke, Model 5720A (5700A/EP) (p/o MIS-35947); w amplifier, Fluke 5725A/AR (5725A/AR)
FREQUENCY COUNTER	Range: 49.4 Hz to 1.033 MHz Accuracy: $\pm 0.25\%$	Fluke, Model PM6681/656 (PM6681/656)
MULTIMETER	Ac voltage: Range: 100 μ V to 700 V ac Accuracy: (Used as null meter) Dc voltage: Range: 0 to 200 V dc Accuracy: 0.017%	Hewlett-Packard, Model 3458A (3458A)
RATIO TRANSFORMER	Range: 0 to 1.000000 Frequency: 1 kHz Accuracy: $\pm 0.0075\%$	ESI, Model DT72A (7915908)
RESISTANCE STANDARD	Range: 20 Ω to 200 Ω	Biddle-Gray, Model 71-631 (7910328)
TRUE RMS VOLTMETER	Range: 0.001 to 11 V Frequency: 1.0520 MHz Accuracy: $\pm 2.5\%$	John Fluke, Model 8922A/AA (8922A/AA)

¹Transfer level requirement only.

SECTION III

CALIBRATION PROCESS FOR AC CALIBRATOR, FLUKE, MODEL 5200A

6. Preliminary Instructions

a. The instruction outlined in paragraphs 6 and 7 are preparatory to the calibration process. Personnel should become familiar with the entire bulletin before beginning the calibration.

b. Items of equipment used in this procedure are referenced within the text by common name as listed in table 2.

c. Unless otherwise specified, verify the result of each test and, whenever the test requirement is not met, take corrective action before continuing with the calibration. Adjustments required to calibrate the TI are included in this procedure. Additional maintenance information is contained in the manufacturer's manual for this TI.

d. When indications specified in paragraphs 8 through 12 are not within tolerance, perform power supply check prior to making adjustments. If adjustments are made, repeat paragraphs 8 through 12. Do not perform power supply check if parameter is within tolerance.

e. Unless otherwise specified, all controls and control settings refer to the TI.

7. Equipment Setup

WARNING

HIGH VOLTAGE is used or exposed during the performance of this calibration. DEATH ON CONTACT may result if personnel fail to observe safety precautions. REDUCE OUTPUT(S) to minimum after each step within the performance check where applicable.

a. Remove protective cover from TI only when necessary to make adjustments. Replace cover after completing the adjustments.

b. Connect TI to 115 V ac power source.

c. Position controls as listed in (1) through (7) below:

- (1) **POWER** switch to **ON**.
- (2) **MODE** switch to **STDBY**.
- (3) **CONTROL** switch to **LOCAL**.
- (4) **PHASE LOCK** switch to **OFF**.
- (5) **SENSE** switch to **INT**.

TB 9-6625-1976-35

(6) **VOLTAGE ERROR**-% switch to **OFF**.

(7) **VERNIER** control to **0** (zero).

d. Allow 1 hour for equipment to warm-up and stabilize.

8. Frequency Accuracy

a. Performance Check

(1) Connect frequency counter to **COUNTER OUTPUT** (rear of TI).

(2) Set **VOLTAGE RANGE** switch to **10 V** and **VOLTAGE** dials to **10.00000**.

(3) Set **FREQUENCY RANGE-Hz** switch to **100**, **FREQUENCY** dials to **50.00 Hz**, and **MODE** switch to **OPER**.

(4) If frequency counter does not indicate between 19.7628 and 20.2429 ms, perform **b** below.

(5) Repeat technique of (2) through (4) above for each frequency listed in table 3.

(6) Set **MODE** switch to **STDBY**.

Table 3. Frequency Accuracy

Test instrument		Frequency counter indications	
FREQUENCY RANGE-HZ switch settings	FREQUENCY dials (Hz)	Min	Max
100	100.00	9.8912 ms	10.1112 ms
1 K	.5000 K	1.9763 ms	2.0243 ms
1 K	1.0000 K	0.9891 ms	1.0111 ms
10 K	5.000 K	4.940 kHz	5.060 kHz
10 K	10.000 K	9.890 kHz	10.110 kHz
100 K	50.00 K	49.400 kHz	50.600 kHz
100 K	100.00 K	98.900 kHz	101.100 kHz
1 M	.5000 M	482.000 kHz	518.000 kHz
1 M	1.0000 M	967.000 kHz	1.033000 MHz

b. Adjustments

(1) Connect true rms voltmeter to **QUADRATURE OUT** (rear of TI).

(2) Set true rms voltmeter **FUNCTION** pushbutton to **FILT OUT**.

(3) Connect frequency counter to **COUNTER OUT** (rear of TI).

(4) Set **FREQUENCY RANGE-Hz** switch to **1 M** and **FREQUENCY** dials to **1.0520 MHz**.

(5) If frequency counter does not indicate between 1.0420 and 1.0620 MHz, adjust A10C41 and A10C45 (fig. 1) in equal amounts in the same direction until frequency counter indicates 1.0520 MHz (R).

(6) If true rms voltmeter does not indicate between 9 and 11 V, adjust A10C41 and A10C45 (fig. 1) in equal amounts in opposite directions until true rms voltmeter indicates 10 V (R).

NOTE

Interaction exists between (5) and (6) above; repeat until the indications converge.

(7) Set **FREQUENCY RANGE-Hz** switch to **100 K** and **FREQUENCY** dials to **80.00 kHz**.

(8) If frequency counter does not indicate between 79.6 and 80.4 kHz, adjust A10C42 (fig. 1) for a counter indication of 80 kHz (R).

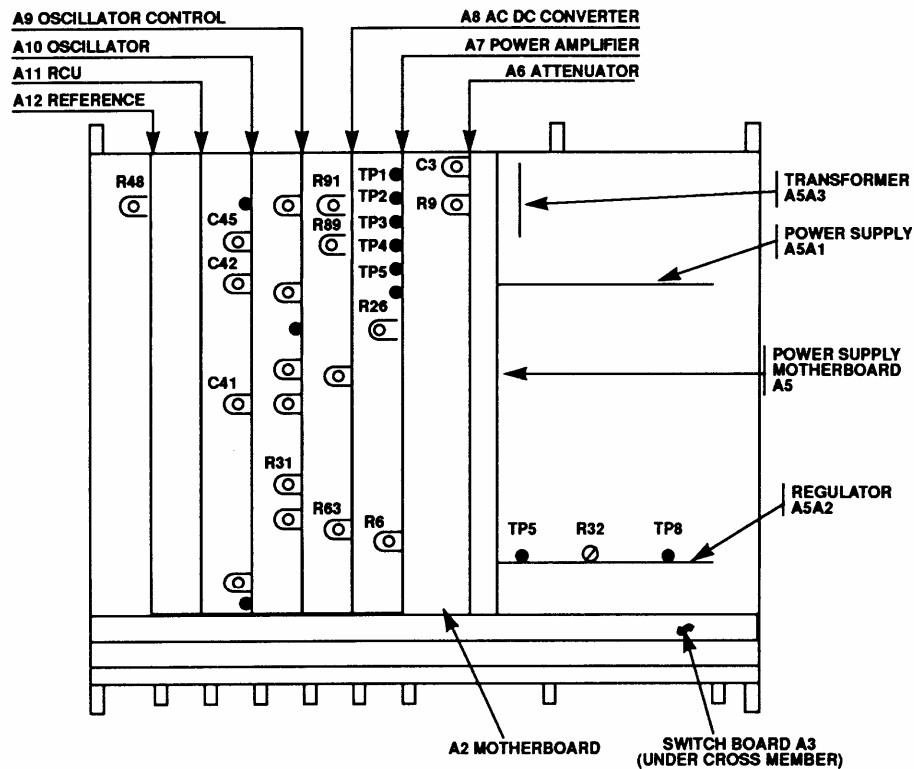

Figure 1. Ac calibrator - adjustment locations.

9. Distortion

a. Performance Check

- (1) Connect TI **OUTPUT** to audio analyzer **HIGH** and **LOW INPUT** terminals using a balanced cable.
- (2) Press audio analyzer **FLOAT** key (assure illumination).
- (3) Set **FREQUENCY RANGE-Hz** switch to **100 kHz** and **FREQUENCY** dials to **50.00 K**.
- (4) Set **VOLTAGE RANGE** switch to **100 V** and **VOLTAGE** dials to **10.0000 V**.
- (5) Set **SENSE** switch to **INT** and **MODE** switch to **OPER**.
- (6) Measure distortion. If distortion is not less than 0.041 percent, perform **b** below.
- (7) Adjust resistance standard to 200 Ω and connect across TI output.
- (8) Measure distortion. If distortion is not less than 0.07 percent, perform **b** below.
- (9) Repeat technique of (1) through (8) above for settings and indications listed in table 4.

Table 4. Distortion

Test instrument				Resistance standard settings (Ω)	Audio analyzer indications	
FREQUENCY RANGE-HZ switch settings	FREQUENCY dials (Hz)	VOLTAGE RANGE switch settings (V)	VOLTAGE dials (V)		No load (%)	With load (%)
100	20.0	1	1.000000	- - -	<0.081	- - -
100 K	20 K	1	1.000000	20	<0.041	<0.1
100 K	50.00 K	1	1.000000	20	<0.041	<0.19
100 K	20 K	10	10.00000	200	<0.041	<0.046
100 K	50.00 K	10	10.00000	200	<0.041	<0.055
100 K	20 K	100	100.0000	- - -	<0.041	- - -

b. Adjustments

CAUTION

In the following check, TP4 and TP5 are floating at approximately + 190 V dc above chassis ground. Isolate the multimeter from chassis ground and use appropriate precautions.

- (1) Connect multimeter between A7TP4 (LO) and A7TP5 (HI) (fig. 1) of the power amplifier board.

- (2) Set **FREQUENCY RANGE-Hz** switch to **100 K** and **FREQUENCY** dials to **100.00 kHz**.
- (3) Set **VOLTAGE RANGE** switch to **100 V** and **VOLTAGE** dials to **10.0000 V**.
- (4) If multimeter does not indicate between 0.34 and 0.36 V dc, adjust A7R26 (fig. 1) for multimeter indication of 0.35 V dc (R).
- (5) Set **FREQUENCY** dials to **50.00 kHz**.
- (6) Measure distortion. Adjust A9R31 (fig. 1) for minimum distortion (R).
- (7) Connect multimeter to **TI OUTPUT** and **SENSE** terminals, using two cables.
- (8) Set **FREQUENCY RANGE-Hz** switch to **1 kHz** and **FREQUENCY** dials to **1.0 K**.
- (9) Set **VOLTAGE RANGE** switch to **10 V**, **VOLTAGE** dials to **10.00000 V** and **SENSE** switch to **EXT**.
- (10) If multimeter does not indicate between $\pm 100 \mu\text{V}$ dc, adjust A7R6 (fig. 1) for a within-tolerance indication (R).

10. Voltage Accuracy and Linearity (Reference Level Only)

a. Performance Check

- (1) Connect **TI OUTPUT** and **SENSE HI** terminals to the ac measurement standard **INPUT 2 HI** terminal and connect the **TI OUTPUT** and **SENSE LO** terminals to the ac measurement standard **INPUT 2 LO** terminal. Press ac measurement standard **INPUT 2** pushbutton.
- (2) On ac measurement standard, press the **UTIL MENUS** pushbutton then the **MEAS CONTROL** soft key. Set **DIGITAL FILTER MODE** to **FAST** and **RESTART** to **MEDIUM**. Push the **DONE** soft key twice to return to the measurement display and set to **AUTO** range.
- (3) Set **FREQUENCY RANGE-Hz** switch to **1 kHz** and **FREQUENCY** dials to **1.0000 K**.
- (4) Set **VOLTAGE RANGE** switch to **1 V**, **VOLTAGE** dials to **1.000000 V**, and **VOLTAGE ERROR-%** switch to **OFF**.
- (5) Set **SENSE** switch to **EXT** and **MODE** switch to **OPER**.
- (6) Measure TI output. If ac measurement standard does not indicate between 0.99978 and 1.00022 V, perform **b** (1) through (5) below.
- (7) Set **MODE** switch to **STDBY**.
- (8) Repeat technique of (3) through (7) above, using settings and indications listed in table 5.

Table 5. Voltage Accuracy

Test Instrument				VOLTAGE dials	AC measurement std indications		Out-of- tolerance adjustment sequence
Step	FREQUENCY RANGE-Hz switch settings	FREQUENCY dials (Hz)	VOLTAGE RANGE switch settings		Min	Max	
1	1 K	1.0000 K	10 V	1.00000	0.9996 V	1.0004 V	b(1) thru (5)
2	1 K	1.0000 K	10 V	10.00000	9.9978 V	10.0022 V	
3	1 K	1.0000 K	100 V	100.0000	99.978 V	100.022 V	b(6) and (7)
4	1 M	1.0000 M	10 V	10.00000	9.964 V	10.036 V	b(8) thru (12)
5	1 M	1.0000 M	10 V	1.00000	0.9937 V	1.0063 V	
6	1 M	1.0000 M	1 V	1.00000	0.9964 V	1.0036 V	b(13) and (14)
7	1 M	1 M	100 V	10.0000	9.937 V	10.063 V	b(15) and (16)
8	1 M	.300 M	100 V	10.0000	9.937 V	10.063 V	
9	100	20	100 V	10.0000	9.985 V	10.015 V	
10	100	100	10 V	10.0000	9.9978 V	10.0022 V	
11	10 K	10 K	10 V	10.0000	9.9978 V	10.0022 V	
12	100 K	90.00 K	1 V	1.00000	0.99945 V	1.00055 V	
13	100 K	30.00 K	1 V	1.00000	0.99945 V	1.00055 V	
14	10 K	10 K	1 V	1.00000	0.99978 V	1.00022 V	
15	1 K	400	1 V	1.00000	0.99978 V	1.00022 V	
16	100	20	1 V	1.00000	0.99895 V	1.00105 V	
17	1 K	1.0000 K	100 mV	100.0000	99.97 mV	100.03 mV	
18	100 K	30.00 K	100 mV	100.0000	99.93 mV	100.07 mV	
19	100 K	90.00 K	100 mV	100.0000	99.93 mV	100.07 mV	
20	1 M	.300 M	100 mV	100.0000	99.64 mV	100.36 mV	
21	1 K	1.0000 K	10 mV	10.0000	9.988 mV	10.012 mV	
22	100 K	30.00 K	10 mV	10.0000	9.975 mV	10.025 mV	
23	100 K	90.00 K	10 mV	10.0000	9.975 mV	10.025 mV	
24	1 M	.300 M	10 mV	10.0000	9.937 mV	10.063 mV	
25	1 K	1.0000 K	1 mV	1.0000	0.9898 mV	1.0102 mV	
26	1 M	.300 M	1 mV	1.0000	0.9667 mV	1.0333 mV	

b. Adjustments (figure 1)

NOTE

Adjustments sequenced together interact with each other and should be adjusted until the indications converge.

- (1) Set **VOLTAGE RANGE** to **10 V** and **VOLTAGE** dials to **1.00000 V**.
- (2) Adjust A8R63 for TI measured output of between 0.99995 and 1.00005 V (R).
- (3) Set **VOLTAGE** dials to **10.0000 V**.
- (4) Adjust A12R48 for TI measured output of between 9.9995 to 10.0005 V (R).

(5) Repeat steps 1 and 2 of table 5, if indications are out-of-tolerance, and repeat **b** (1) through (4) above until an in-tolerance condition is achieved.

(6) Set **VOLTAGE RANGE** switch to **100 V** and **VOLTAGE** dials to **100.0000 V**.

(7) Adjust A6R9 for TI measured output of between 99.995 and 100.005 V (R).

(8) Set **FREQUENCY RANGE-Hz** switch to **1 MHz** and **FREQUENCY** dials to **1.0000 M**.

(9) Set **VOLTAGE RANGE** switch to **10 V** and **VOLTAGE** dials to **10.00000 V**. Measure and record error of TI output.

(10) Set **VOLTAGE** dials to **1.00000 V**. Measure and record error of TI output.

(11) If indication recorded in (10) above is not within ± 0.02 percent of indication recorded in (9) above, adjust A8R89 (R).

(12) Repeat steps 4 and 5 of table 5, if indications are out of tolerance, and repeat (9) through (11) above until an in-tolerance condition is achieved.

(13) Set **VOLTAGE RANGE** switch to **1 V** and **VOLTAGE** dials to **1.000000 V**.

(14) Adjust A8R91 for TI measured output of between 0.9999 and 1.0001 V (R).

(15) Set **VOLTAGE RANGE** switch to **100 V** and **VOLTAGE** dials to **10.0000 V**.

(16) Adjust A6C3 for TI measured output of 9.967 V (R).

11. Voltage Accuracy and Linearity (Transfer Level Only)

a. Performance Check

(1) Execute multimeter **ACAL AC** command and after execution set multimeter for **SETACV SYNC** mode of measurement.

(2) Connect calibrator **OUTPUT** to multimeter **VOLTS INPUT** terminals.

(3) Press multimeter **FUNCTION/RANGE Range** \uparrow or \downarrow keys to manual 1.0 V range.

CAUTION

Ensure that multimeter manual range is appropriately set prior to applying voltage.

(4) Set calibrator for a 1.0 V, 1.0 kHz output.

(5) Allow multimeter to take at least three readings (samples); then set multimeter to **NULL** function.

NOTE

If multimeter does not have the keyboard overlay with the **NULL** function preprogrammed, you will have to access the **MATH** function through the **MENU** command and enable **MATH NULL**.

(6) Disconnect calibrator and connect TI **OUTPUT** to multimeter **Input (2 WIRE)** terminals.

(7) Set TI as listed in (a) through (g) below:

(a) **FREQUENCY RANGE-Hz** switch to **1 kHz**.

(b) **FREQUENCY** dials to **1.0000**.

(c) **VOLTAGE RANGE** switch to **1 V**.

(d) **VOLTAGE** dials to **1.000000 V**.

(e) **VOLTAGE ERROR-%** switch to **OFF**.

(f) **SENSE** switch to **INT**.

(g) **MODE** switch to **OPER**.

(8) Allow multimeter to take at last three readings (samples). Multimeter will indicate 0 V (± 0.00122 V); if not, perform steps 1 and 2 of table 6 and **b** (1) through (5) below.

(9) Repeat technique of (2) through (8) above for remaining steps listed in table 6, using settings and values specified.

Table 6. Voltage Accuracy (Transfer Level)

Step	Calibrator output		Test instrument				Multimeter indications (V)	Adjustment
	Volts (V)	Frequency	FREQUENCY RANGE-Hz switch	FREQUENCY dials (Hz)	VOLTAGE RANGE switch (V)	Voltage dials (V)	0 (null) \pm volts (V)	
1	1.0	1.0 kHz	1 K	1.0000 K	10	1.00000	0.00140	b(1)
2	10	1.0 kHz	1 K	1.0000 K	10	10.00000	0.01220	b(2) and (3)
3	100	1.0 kHz	1 K	1.0000 K	100	100.0000	0.1220	b(4)
4	10	1.0 MHz	1 M	1.0000 M	10	10.00000	0.1230 ¹	b(5) thru (7)
5	1.0	1.0 MHz	1 M	1.0000 M	10	1.00000	0.0150 ²	
6	1.0	1.0 MHz	1 M	1.0000 M	1	1.00000	0.01230	b(8)

Table 6. Voltage Accuracy (Transfer Level) - Continued

Step	Calibrator output		Test instrument				Multimeter indications (V)	Adjustment	
	Volts (V)	Frequency	FREQUENCY RANGE-Hz switch	FREQUENCY dials (Hz)	VOLTAGE RANGE switch (V)	Voltage dials (V)	0 (null) ±volts (V)		
7	10	1.0 MHz	1 M	1.0000 M	100	10.0000	0.150	b(9)	
8	10	0.30 MHz	1 M	.300 M	100	10.0000	0.150		
9	10	20 Hz	100	20	100	10.0000	0.0170		
10	10	100 kHz	100	100	10	10.00000	0.01220	b(1)	
11	10	10 kHz	10 K	10 K	10	10.00000	0.01220		
12	1.0	100 kHz	100 K	100.00 K	1	1.00000	0.01205		
13	1.0	50 kHz	100 K	50.00 K	1	1.00000	0.00125		
14	1.0	10 kHz	10 K	10 K	1	1.00000	0.01220		
15	1.0	20 Hz	100	20	1	1.00000	0.01220		
16	1.0	1.0 kHz	1 K	1.0000 K	1	1.00000	0.00122 ³		
(Note change in calibrator output)									
Step	Volts (mV)	Frequency	FREQUENCY RANGE-Hz switch	FREQUENCY dials (Hz)	VOLTAGE RANGE switch (mV)	Voltage dials (mV)	0 (null) ±volts (mV)		
17	100	1.0 kHz	1K	1.0000 K	100	100.0000	0.13		
18	10	1.0 kHz	1K	1.0000 K	10	10.0000	0.022		

NOTE: The following % of error data will not be utilized if indications in steps 4 and 5 are within limits:

¹Record multimeter indication, then convert to % of error by multiplying value by 10. If out of tolerance, perform step 5 above prior to performing **b** (7) through (9) below.

²Record multimeter indication, then convert to % of error by multiplying value by 100.

³If indication is within limits, adjust TI **VOLTAGE** dials for the best null indication on multimeter. Record resulting TI **VOLTAGE** dial setting for use in (15) below.

(10) Connect equipment as shown in figure 2.

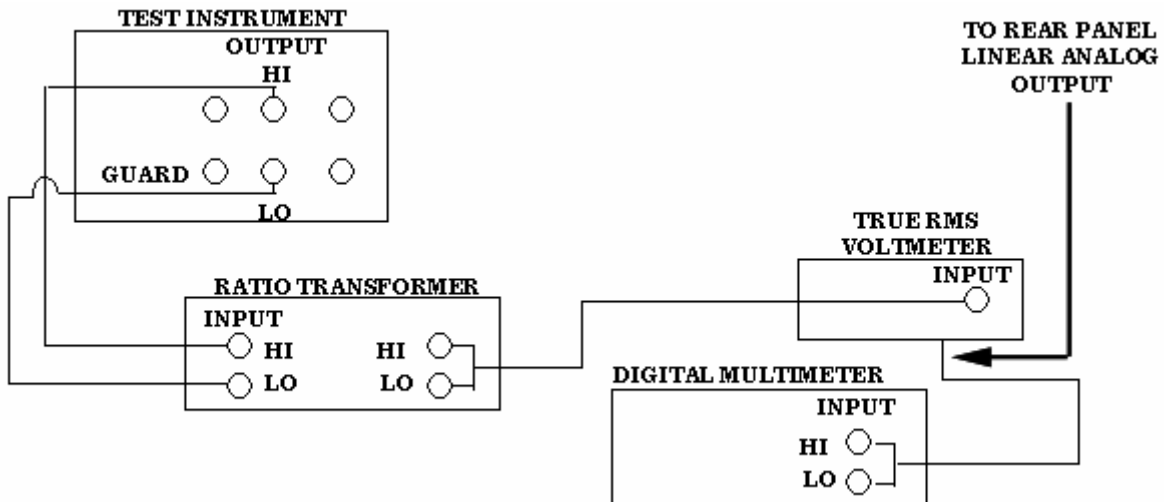

Figure 2. 1 mVAC equipment setup.

TB 9-6625-1976-35

- (11) Press true rms voltmeter **FUNCTION** pushbutton to **FILT IN**.
- (12) Set multimeter for dc voltage measurement.
- (13) Set **SENSE** switch to **INT** and **MODE** switch to **OPER**.
- (14) Set ratio transformer dials to **.1000000**.
- (15) Set TI **VOLTAGE** dials to the setting recorded in step 16 of table 6.
- (16) Establish upper and lower limits for 1 mV range by:
 - (a) Upper limit - Set ratio transformer dials to **.0010102**. Record multimeter indication.
 - (b) Lower limit - Set ratio transformer dials to **.0009898**. Record multimeter indication.
- (17) Set ratio transformer dials to **1.0000000**.
- (18) Set TI **VOLTAGE RANGE** switch to **1 mV** and **VOLTAGE** dials to **1.00000 mV**. Multimeter indication will be within limits recorded in (16) above.

b. Adjustments (figure 1)

NOTE

Adjustments sequenced together (as indicated in table 6) interact with each other and should be adjusted until indications converge.

- (1) Adjust A8R63 for best null indication on multimeter (R).
- (2) Adjust A12R48 for best null indication on multimeter (R).
- (3) Repeat steps 1 and 2 of table 6 and **b** (1) and (2) above, as necessary, until both indications are within limits.
- (4) Adjust A6R9 for best null indication on multimeter (R).
- (5) Ensure that **VOLTAGE RANGE** switch is set to **10 V** and **VOLTAGE** dials to **1.00000 V (1 MHz)**.
- (6) Adjust A8R89 for the same error as recorded in step 4 of table 6 (10 V, 1 MHz) $\pm 0.2\%$ (R).
- (7) Repeat technique of steps 4 and 5 of table 6 and **b** (5) and (6) above until they can be performed without adjustments.

- (8) Adjust A8R91 for best null indication on multimeter (R).
- (9) Adjust A6C3 for a ± 0.033 (± 5 digits) indication on multimeter (R).

12. Power Supply

NOTE

Do not perform power supply checks if all other parameters are within tolerance.

a. Performance Check

- (1) Connect multimeter to REGULATOR A5A2TP8 (HI) and A5A2TP5 (LO) (fig. 1)
- (2) Set **MODE** switch to **OPER**. If the multimeter does not indicate between 14.99 and 15.01 V dc, perform **b** (1) below.
- (3) Move multimeter (HI) lead from A5A2TP8 to A7TP3 (fig. 1). If multimeter does not indicate between 185 to 200 V dc, perform **b** (2) below.
- (4) Set **MODE** switch to **STDBY**.

b. Adjustments

- (1) Adjust A5A2R32 (fig. 1) for a 15 ± 0.01 V dc indication on multimeter (R).
- (2) Adjust A5A2R32 (fig. 1) for a minimum indication on multimeter of 185 V up to 220 V dc (R).

13. Final Procedure

- a. Deenergize and disconnect all equipment.
- b. Annotate and affix DA label/form in accordance with TB 750-25.

SECTION IV CALIBRATION PROCESS FOR PRECISION POWER AMPLIFIERS, JOHN FLUKE, MODELS 5215A AND 5205A

14. Preliminary Instructions

- a. The instructions outlined in paragraphs 14 and 15 are preparatory to the calibration process. Personnel should become familiar with the entire bulletin before beginning the calibration.
- b. Items of equipment used in this procedure are referenced within the text by common name as listed in table 2.

TB 9-6625-1976-35

c. Unless otherwise specified, verify the results of each test and, whenever the test requirement is not met, take corrective action before continuing with the calibration. Adjustments required to calibrate the TI are included in this procedure. Additional maintenance information is contained in the manufacturer's manual for this TI.

d. When indications specified in paragraphs **16** and **18** are not within tolerance, perform the power supply check in paragraph **19** prior to making adjustments. After adjustments are made, repeat paragraphs **16** (or **17**) and **18**. Do not perform power supply check if all other parameters are within tolerance.

e. Unless otherwise specified, all controls and control settings refer to the TI.

15. Equipment Setup

WARNING

HIGH VOLTAGE is used or exposed during the performance of this calibration. DEATH ON CONTACT may result if personnel fail to observe safety precautions. REDUCE OUTPUT(S) to minimum after each step within the performance check where applicable.

a. Remove protective cover on TI, as required, for making adjustments.

b. Connect TI to ac calibrator, model 5200A. The calibrator should be the one normally used with the TI and should have been recently calibrated.

c. Connect TI and ac calibrator to a 115 V ac source.

16. High Voltage Accuracy (Reference Level)

a. Performance Check

(1) Connect TI output connector to the ac measurement standard **INPUT 2 HI** and **INPUT 2 LO** terminals. Press ac measurement standard **INPUT 2** pushbutton.

NOTE

Ensure that **OUTPUT LOW** and **GUARD** terminal connecting strap is securely in place on TI.

(2) Set both TI and ac calibrator **POWER** switches to **ON**. Allow at least 1 hour for equipment to warm-up and stabilize.

NOTE

The operation of the TI is controlled by the ac calibrator. The TI controls referred to in the remainder of the check are located on the ac calibrator.

- (3) Manually lock ac measurement standard to 700 V range.
- (4) Position controls as listed in (a) through (e) below:
 - (a) **FREQUENCY RANGE** switch to **10 kHz**.
 - (b) **FREQUENCY** dials to **1.000 K**.
 - (c) **VOLTAGE RANGE** switch to **1000 V**.
 - (d) **VOLTAGE** dials to **500.000 V**.
 - (e) **MODE** switch to **OPER**.
- (5) Measure TI output. If ac measurement standard does not indicate between 499.78 and 500.22 V, perform **b** (1) below.
- (6) Repeat technique of (4) through (5) above using frequencies listed in table 7.

Table 7. High Voltage Accuracy

Test instrument frequency	AC Measurement std indications	
	Min	Max
30 Hz	499.78	500.22
400 Hz	499.78	500.22
30 kHz	499.55	500.45
50 kHz	499.55	500.45

- (7) Set TI for a 500 V, 100 kHz output. If ac measurement standard does not indicate between 499.40 and 500.60 V, perform **b** (2) below.

b. Adjustments

- (1) Adjust R9, LF GAIN (fig. 3) for TI measured output of 500 Vac (R).
- (2) Adjust C14, HF GAIN (fig. 3) for TI measured output of 500 Vac (R).

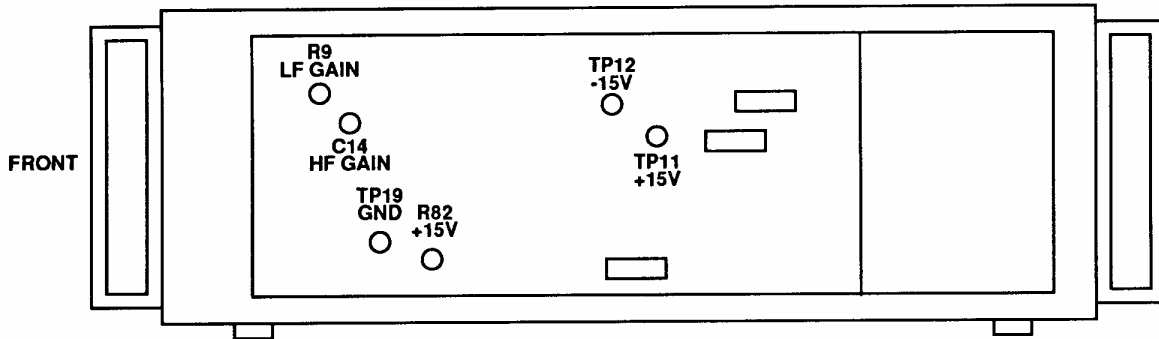

Figure 3. Precision power amplifier, Fluke, Model 5215A - adjustment locations.

17. High Voltage Accuracy (Transfer Level Only)

a. Performance Check

- (1) Execute multimeter **ACAL AC** command and after execution set multimeter for **SETACV SYNC** mode of measurement.
- (2) Connect calibrator **OUTPUT** to multimeter **VOLTS INPUT** terminals.
- (3) Press multimeter **FUNCTION/RANGE Range** \uparrow or \downarrow keys to manual 1000 V range.

CAUTION

Ensure that multimeter manual range is set to 1000 V prior to applying voltage.

- (4) Set calibrator for a 700 V, 1.0 kHz output.
- (5) Allow multimeter to take at least three readings (samples); then set multimeter to **NULL** function.

NOTE

If multimeter does not have the keyboard overlay with the **NULL** function preprogrammed, you will have to access the **MATH** function through the **MENU** command and enable **MATH NULL**.

- (6) Disconnect calibrator and connect **TI OUTPUT** to multimeter **Input (2 WIRE)** terminals.
- (7) Set TI as listed in (a) through (e) below:
 - (a) **FREQUENCY RANGE-Hz** switch to **10 kHz**.
 - (b) **FREQUENCY** dials to **1.0000**.

- (c) **VOLTAGE RANGE** switch to **1000 V**.
- (d) **VOLTAGE** dials to **700.000 V**.
- (e) **MODE** switch to **OPER**.

(8) Allow multimeter to take at least three readings (samples). Multimeter will indicate 0 V (± 4.000 V); if not, perform **b** (1) below.

(9) Repeat technique of (4) through (8) above for remaining values listed in table 8, using settings and values specified.

CAUTION

Ensure that multimeter remains in manual 1000 V range.

Table 8. High Voltage Accuracy (Transfer Level Only)

Calibrator output		Test instrument frequency	Multimeter indications 0 (null) \pm volts (V)
Volts (V)	Frequency		
700	1.0 kHz	1.0 kHz	4.000
700	20 Hz	20 Hz	4.000
500	10 kHz	10 kHz	0.600
700	10 kHz	10 kHz	4.000
700	50 kHz	50 kHz	1.200
700	100 kHz	100 kHz	12.000 ¹

¹If out of tolerance, perform **b** (2) below.

b. Adjustments

- (1) Adjust R9, LF GAIN (fig. 3) for best null indication on multimeter (R).
- (2) Adjust C14, HF GAIN (fig. 3) for best null indication on multimeter (R).

18. Distortion

a. Performance Check

- (1) Connect TI **OUTPUT** lead to audio analyzer **INPUT** terminal(s).
- (2) Set for a 300 V, 20 Hz output. Measured distortion will be ≤ 0.1 percent.
- (3) Repeat technique of (2) above for frequencies of 1, 10 and 50 kHz. Measured distortion will be ≤ 0.1 percent.

b. Adjustments. No adjustment can be made.

TB 9-6625-1976-35

19. Power Supply (Model 5215A)

a. Performance Check

NOTE

Do not perform power supply checks if all other parameters are within tolerance.

(1) Connect multimeter between TP11 +15V and TP 19 GRD (fig. 3). If multimeter does not indicate between 14.95 and 15.05 V, perform **b** below.

(2) Connect multimeter between TP 12 - 15 V and TP 19 GND (fig. 3). Multimeter will indicate between -14.65 and -15.35 V.

b. Adjustments. Adjust R82 +15V (fig. 3) for a multimeter indication between +14.95 and 15.05 V dc (R).

20. Final Procedure

a. Deenergize and disconnect all equipment.

b. Annotate and affix DA label/form in accordance with TB 750-25.

By Order of the Secretary of the Army:

Official:



JOEL B. HUDSON
*Administrative Assistant to the
Secretary of the Army*

0421704

PETER J. SCHOOMAKER

*General, United States Army
Chief of Staff*

Distribution:

To be distributed in accordance with the initial distribution number (IDN) 343047, requirements for calibration procedure TB 9-6625-1976-35.

INSTRUCTIONS FOR SUBMITTING AN ELECTRONIC 2028

The following format must be used if submitting an electronic 2028. The subject line must be exactly the same and all fields must be included; however, only the following fields are mandatory: 1, 3, 4, 5, 6, 7, 8, 9, 10, 13, 15, 16, 17, and 27.

From: "Whomever" whomever@redstone.army.mil
To: <2028@redstone.army.mil

Subject: DA Form 2028

1. **From:** Joe Smith
2. **Unit:** home
3. **Address:** 4300 Park
4. **City:** Hometown
5. **St:** MO
6. **Zip:** 77777
7. **Date Sent:** 19-OCT -93
8. **Pub no:** 55-2840-229-23
9. **Pub Title:** TM
10. **Publication Date:** 04-JUL-85
11. **Change Number:** 7
12. **Submitter Rank:** MSG
13. **Submitter FName:** Joe
14. **Submitter MName:** T
15. **Submitter LName:** Smith
16. **Submitter Phone:** 123-123-1234
17. **Problem:** 1
18. **Page:** 2
19. **Paragraph:** 3
20. **Line:** 4
21. **NSN:** 5
22. **Reference:** 6
23. **Figure:** 7
24. **Table:** 8
25. **Item:** 9
26. **Total:** 123
27. **Text**

This is the text for the problem below line 27.

